



KNELSON

Knelson (a corporate partnership)
 19855 - 98th. Avenue, Langley B.C. Canada, V1M 2X5
 Phone: 604-888-4015, Fax: 604-888-4013
 www.KnelsonGravitySolutions.com, E-Mail: knelson@knelson.com

DATE: JUN 17, 2005

DWG. No. A01527A2

PROSPECTING TRAILER c/w KNELSON CONCENTRATOR MODEL KC-MD7.5 & KC-VS7.5

FEED CAPACITY (MAY VARY DEPENDING ON MATERIAL)	- 0 - 1500 lbs/hr [0 - 680 kg/hr] SOLIDS
TYPICAL FLUIDIZATION WATER REQUIREMENT	- 12 - 18 USgpm [45 - 68 Lpm]
FEED DENSITY	- 0 - 75% SOLIDS/WEIGHT
MAXIMUM TOTAL VOLUMETRIC THROUGHPUT	- 25 USgpm [95 Lpm]
FEED SIZE	- 3/16" [4.7mm] MINUS
CONCENTRATE VOLUME	- 30 in ³ [0.5 L]
CONCENTRATE WEIGHT	- 1.6 - 2.2 lbs [0.7 - 1.0 kg]
CONCENTRATOR W/SCREEN NET WEIGHT	- 435 lbs [198 kg]
PROSPECTING TRAILER NET WEIGHT	- 2350 lbs [1068 kg]
CONCENTRATOR H.P.	- 3/4 (ELECTRIC)
VIBRATING SCREEN H.P.	- 1/3 (ELECTRIC)

APPROXIMATE SHIPPING WEIGHT KC-MD7.5 & KC-VS7.5	- 596 lbs [271 kg]
APPROXIMATE SHIPPING WEIGHT FOR KC-MD7.5 & KC-VS7.5 WITH SPARES	- 620 lbs [281 kg]
APPROXIMATE CRATED WEIGHT OF PROSPECTING TRAILER	- 2600 lbs [1180 kg]
APPROXIMATE CRATED SHIPPING DIMENSIONS OF KC-MD7.5 & KC-VS7.5	- LENGTH 125cm x WIDTH 92cm x HEIGHT 155cm
APPROXIMATE CRATED SHIPPING DIMENSIONS FOR PROSPECTING TRAILER	- LENGTH 275cm x WIDTH 229cm x HEIGHT 153cm

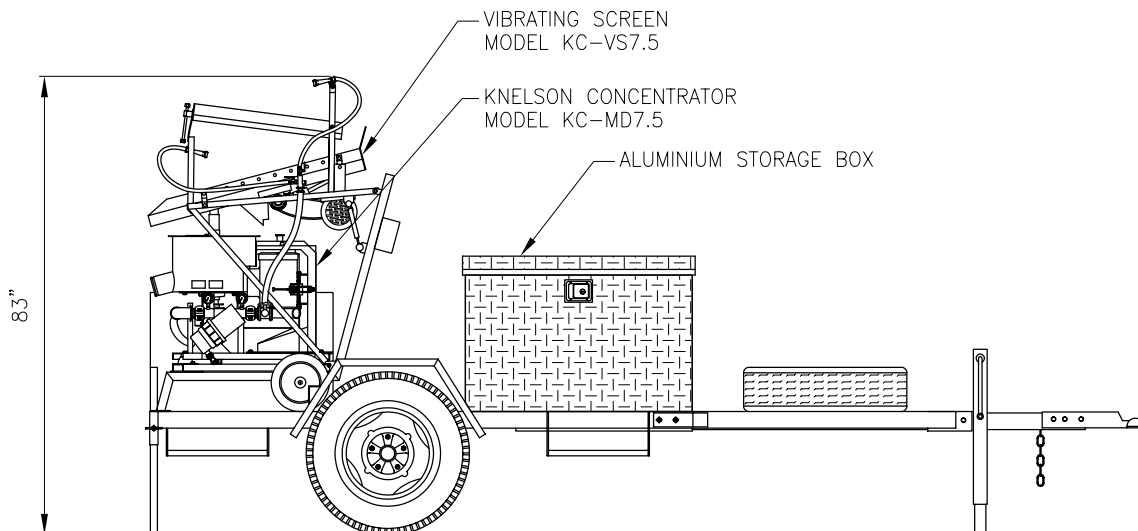
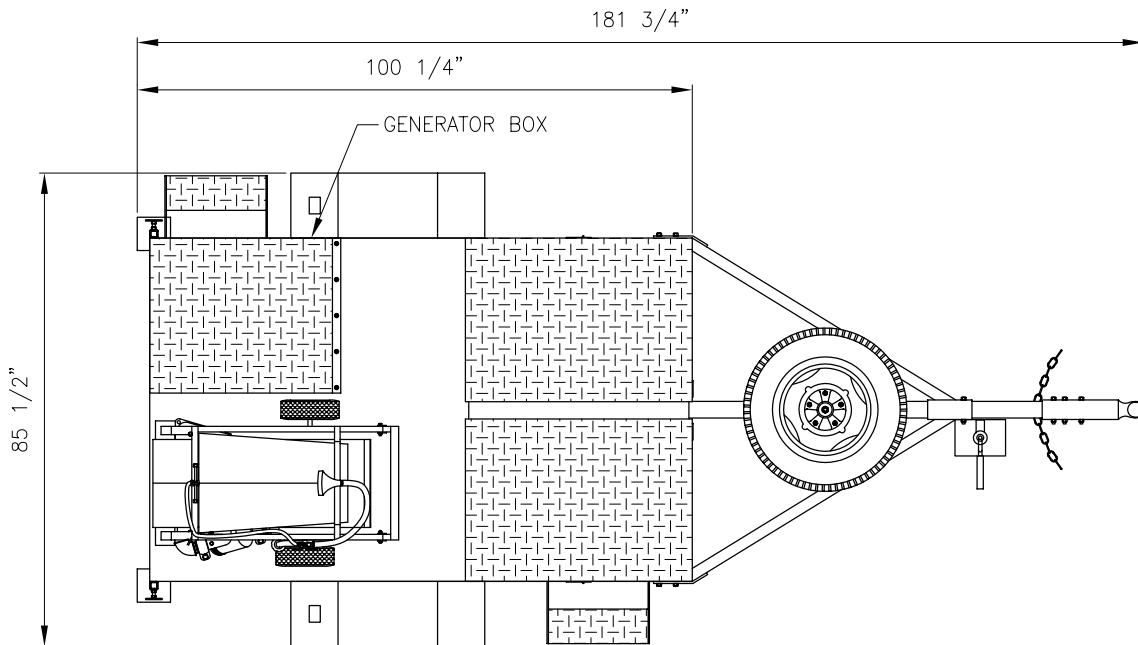
**NOTES:**

- 1) DIMENSIONS SUBJECT TO CHANGE WITHOUT NOTICE, AND ARE FOR REFERENCE ONLY.
- 2) NOT REGISTERED FOR NORTH AMERICAN ROAD USE.